



SOUTH TERRACE Alterations + Additions



LOCATION: Fremantle

SOUTH TERRACE

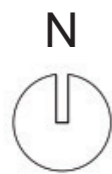

6.37m

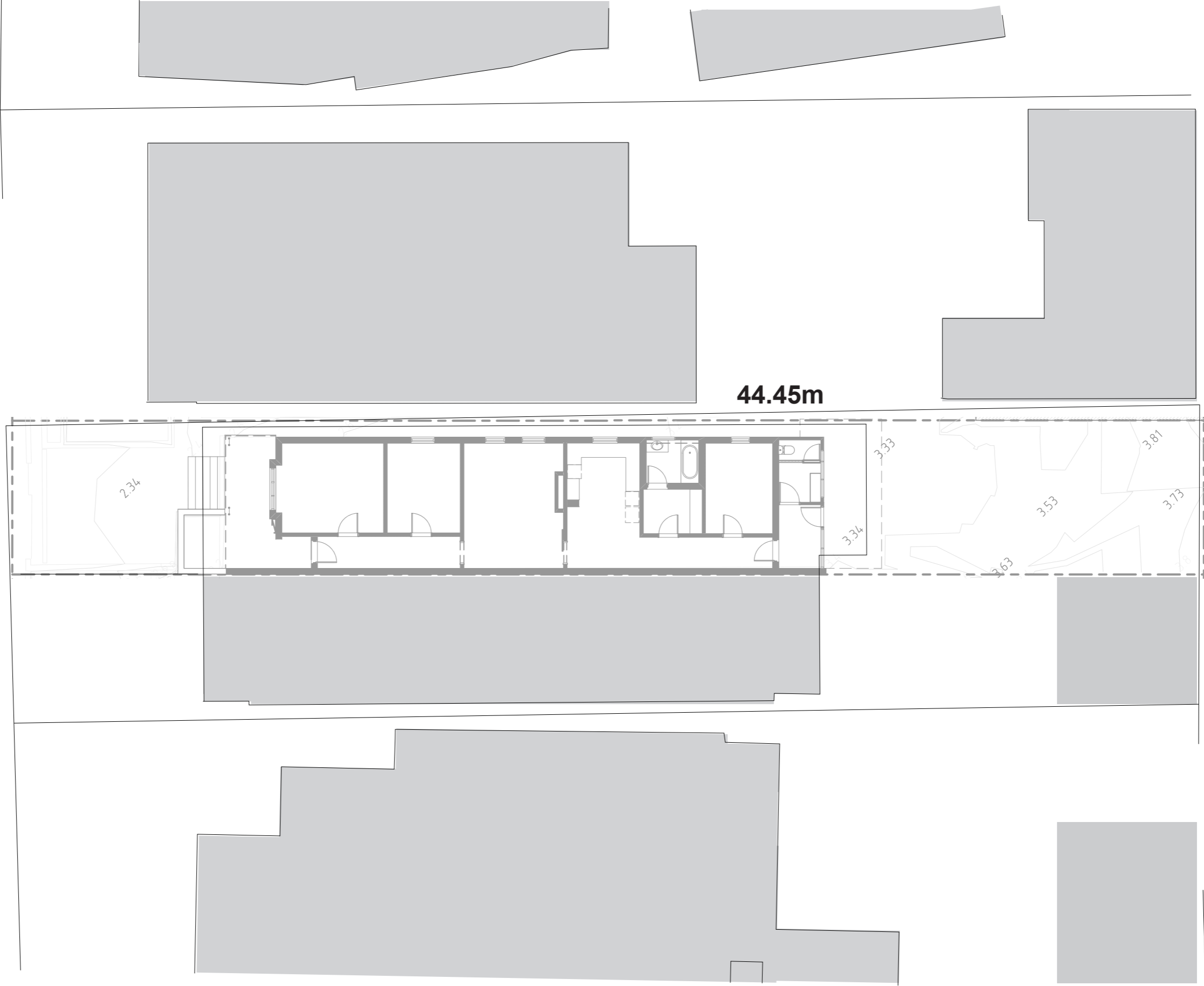

44.45m

R.O.W.

THE SITE



APPROACH:

EXTRACTING AMENITY

North Light -- Natural Ventilation -- Contextual Linkages -- Space -- Garden



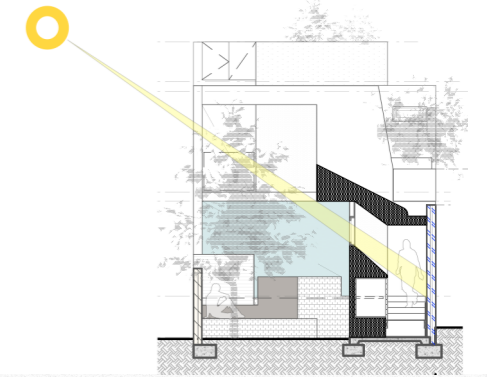
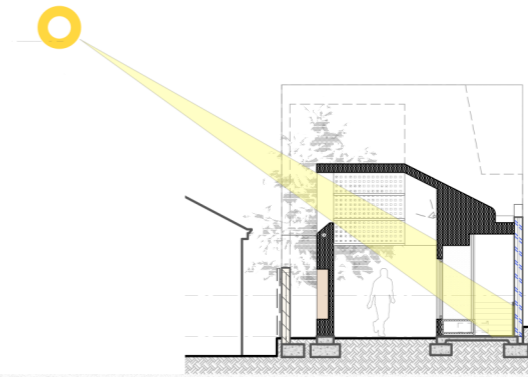
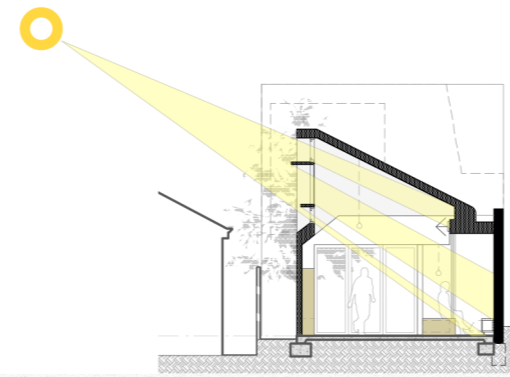

A

B

C

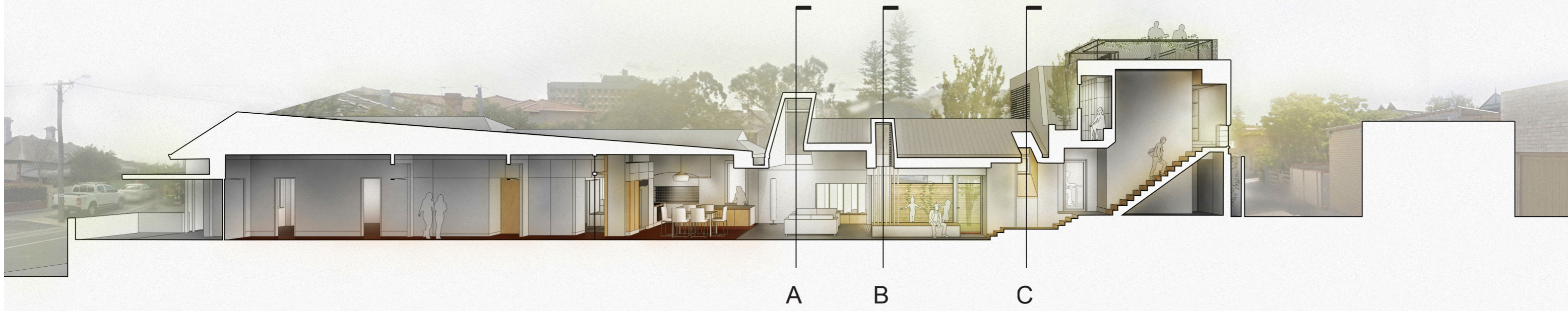

A

B

C

EXTRACTING: North Light



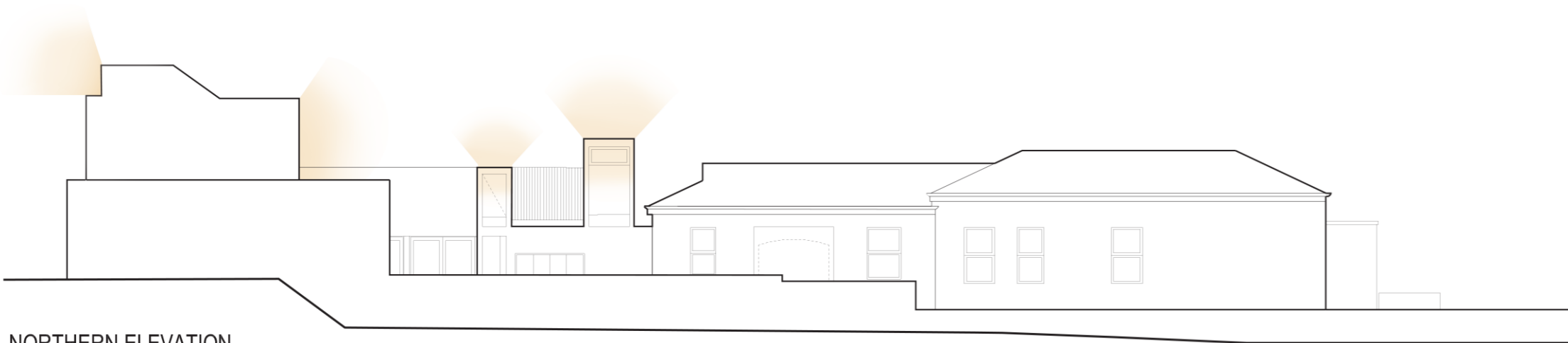

NORTHERN ELEVATION

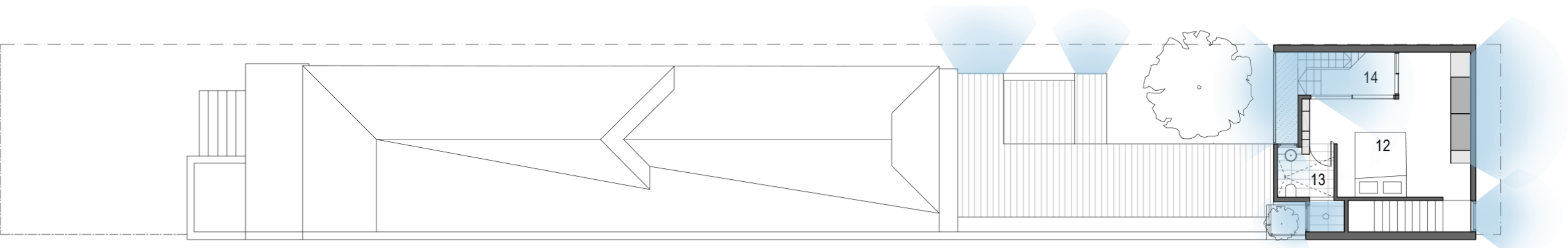

FIRST FLOOR PLAN

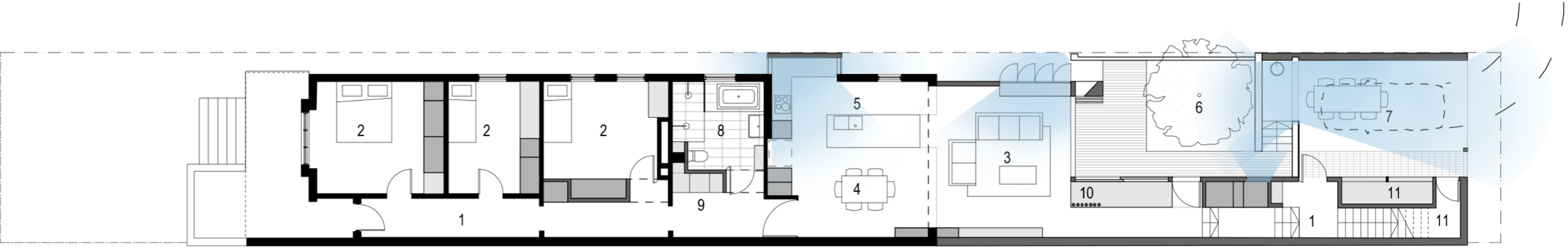

GROUND FLOOR PLAN

EXTRACTING: Natural Ventilation



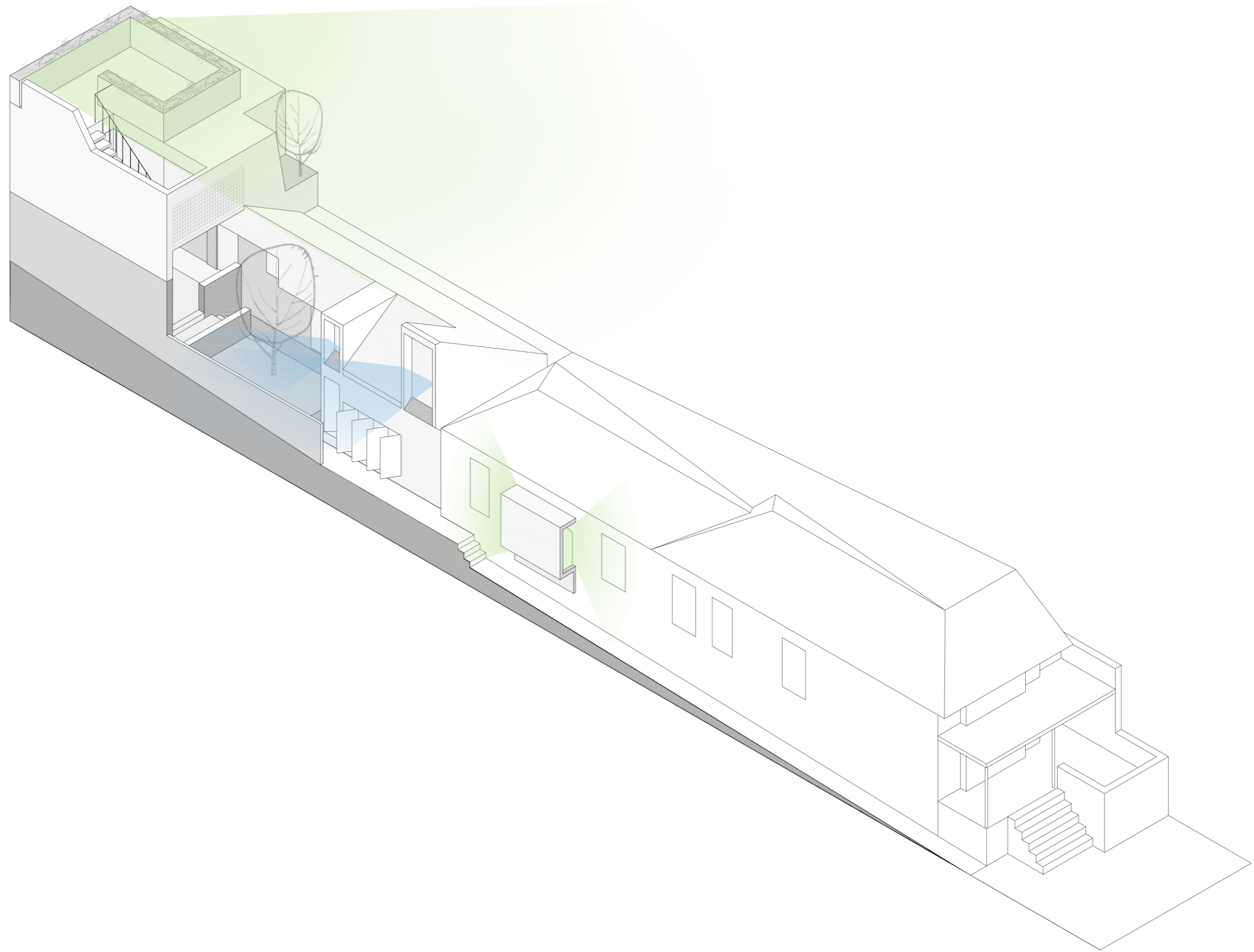

EXTRACTING: Linkages



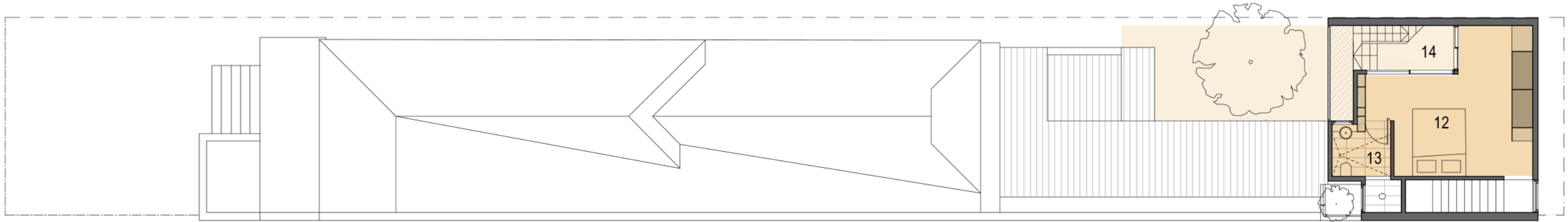

FIRST FLOOR PLAN

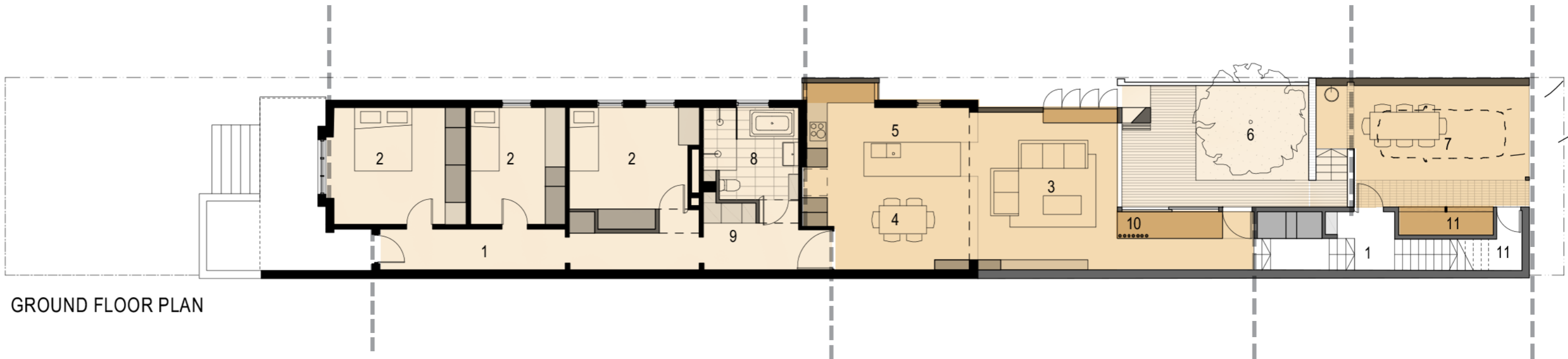

GROUND FLOOR PLAN

EXTRACTING: Spatial Amenity



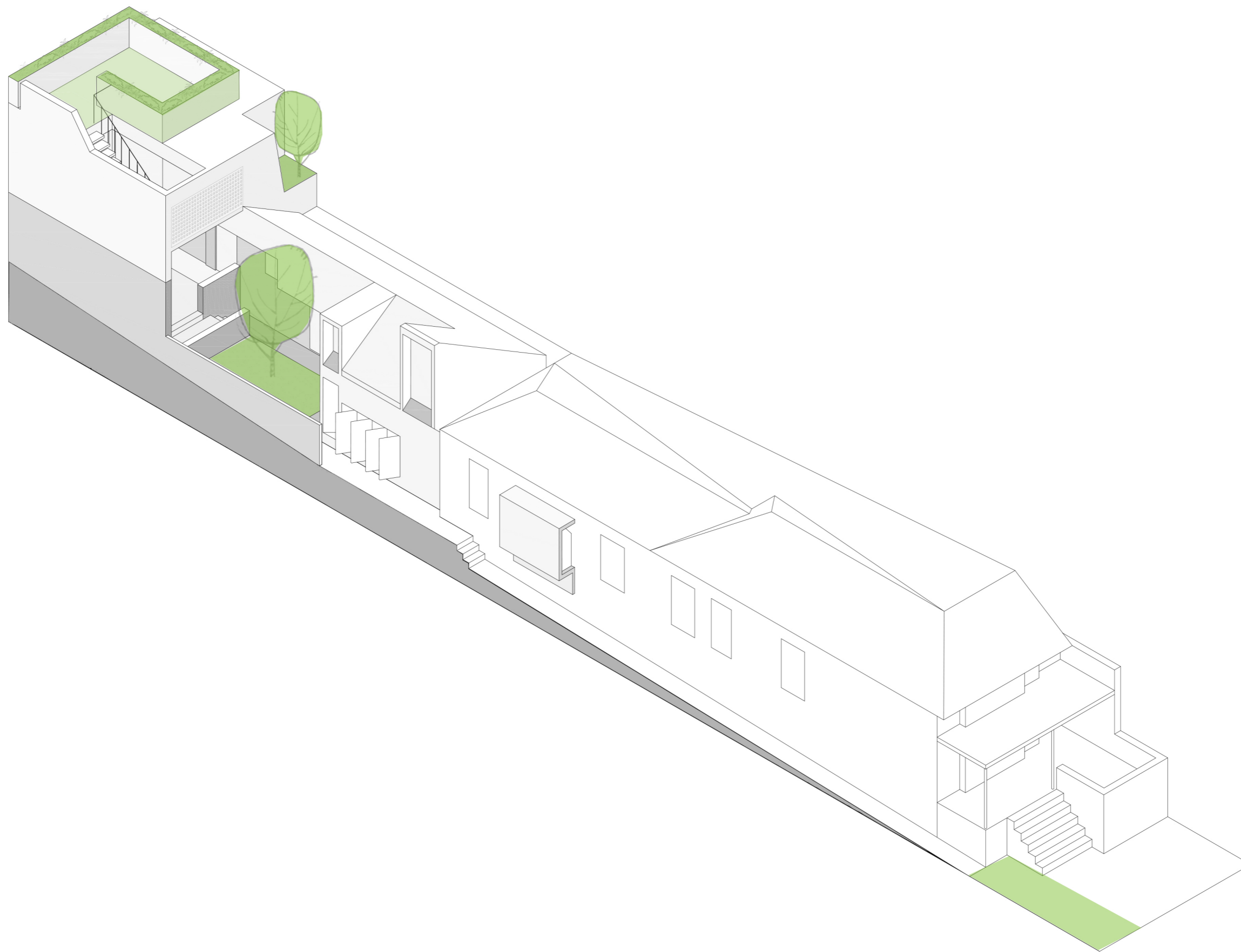

EXTRACTING: Garden

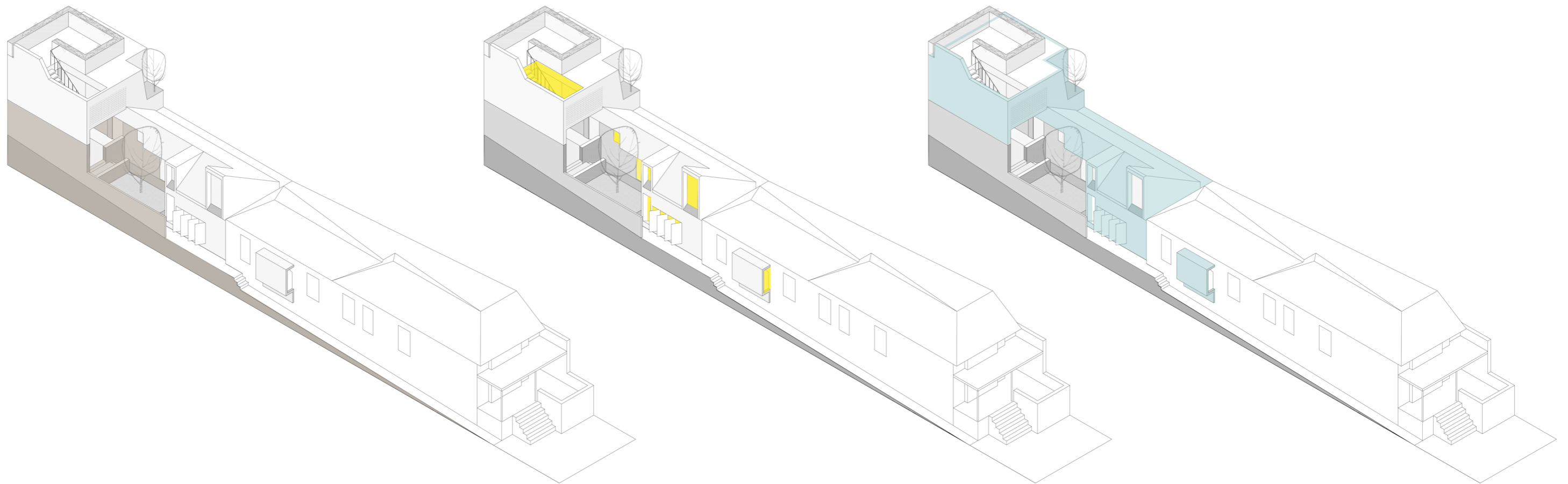

BASE: grounding

LIGHT: connective tissue

LID: unifier

MATERIALITY



















THANK YOU